



DX8210 is Datalogic's new high performance laser bar code reader purpose built to offer to offer top reading performance combined and ease of use to End User and System Integrators specialized in the Transport and Logistics market. Thanks to its unique design, DX8210 offers an ALL-IN-ONE solution for omnidirectional reading stations. This single device is capable of reading codes at any orientation on the conveyor.

With the benefits of state-of-the-art technology and innovative optic design, DX8210 can cover a wide conveyor and large depth of field to satisfy demanding applications. A high scan rate (2000 scans/sec) allows DX8210 to work perfectly on high speed conveyors for mass production.

Thanks to its ALL-IN-ONE architecture, DX8210 offers unmatched ease of installation and ease of use. In just a few minutes, readers can be installed above the conveyor and the onmi-station is ready to work.

The innovative DST (Digital Signal Technology) drastically increases optic performance even in cases where code quality is unpredictable. DST offers stable and constant performance under any working conditions to ensure logistic operators maintain timely deliveries.

Multi-headed tunnel configurations are perfectly managed with EBC (Ethernet Bus Connection), allowing high speed data transmission and real time signal synchronization inside the system. EBC allows redundant configuration, assuring no system deadlock in case of component failure.

Ease of use, automatic setup and system diagnostics are perfectly satisfied thanks to e-GENIUS, the web browser configuration tool that allows you to access the system with a standard web-browser program with no need for specific configuration software.



IDENTIFICATION



## HIGHLIGHTS

- ALL-IN-ONE architecture offering outstanding ease of use and ease of installation
- Single device offering 900x900 mm (36x36 in) omnidirectional reading area
- High scan rate (2000 scans/sec) provides top results on high speed conveyors and in mass production environments
- Excellent performance on low quality code and unpredictable reading conditions
- Unmatchable ease of use and ease of installation
- DST (Digital Signal Technology) offering stable and constant performance under any operative conditions
- ASTRA G3 technology offering superior DoF and FoV without mechanical autofocus
- Ethernet Bus Connections (EBC) for high speed data transmission and real time synchronization
- Fully redundant configuration and no single point of failure
- e-GENIUS web browser programming tools
- Ease of maintenance and automatic replacement

## TARGET MARKETS AND APPLICATIONS

1. Airport Baggage Handling
2. Parcel Sorting
3. Retail Distribution Center
4. Loading/Unloading System
5. Shop Floor and Manufacturing
6. Automatic Warehousing Management

## TECHNICAL SPECIFICATIONS

Max Resolution	600-1850 mm (23-72 in)
Scan Rate	Typ: 1000scans/s/ Max
Scan Pattern Type	X-Pattern
Aperture Angle	60 degrees
Multilabel Reading	Up to 10 different symbologies during the same reading phase
Optic Architecture/Technology	ASTRA G3
Bar Code Assignment Technology	PackTrack™ G2
Reconstruction Code Technology	ACR G5
Readable Codes	22 symbologies including 2/5 family, Code39, Code93, Code128, EAN/UPC, EAN128, ISBN128
Case Material	Aluminum alloy
Dimensions (Typical Value)	381 x 328 x 92.5 mm [15 x 13 x 3.6 in]
Weight	7.7 kg (17 lb)
Temperature Range	0° - 50° C
Power Supply / Consumption	20 to 30 VDC; 20 W
IP rating	IP65
Ethernet	2 x Ethernet TCP/IP
Serial Interfaces	Main Port: RS232 / RS422 up to 115.2 Kbit/s Auxiliary Port: RS232 up to 115.2 Kbit/s
Internal Communication System	EBC Technology
Fieldbus	Embedded EtherNet/IP, PROFINET-IO and PROFIBUS-DP supported
Digital Outputs	2 x Outputs SW programmable, optocoupled, event driven, NPN
Device Programming	Multilanguage, browser-based, on board HTML web server interface

## MECHANICAL DRAWINGS

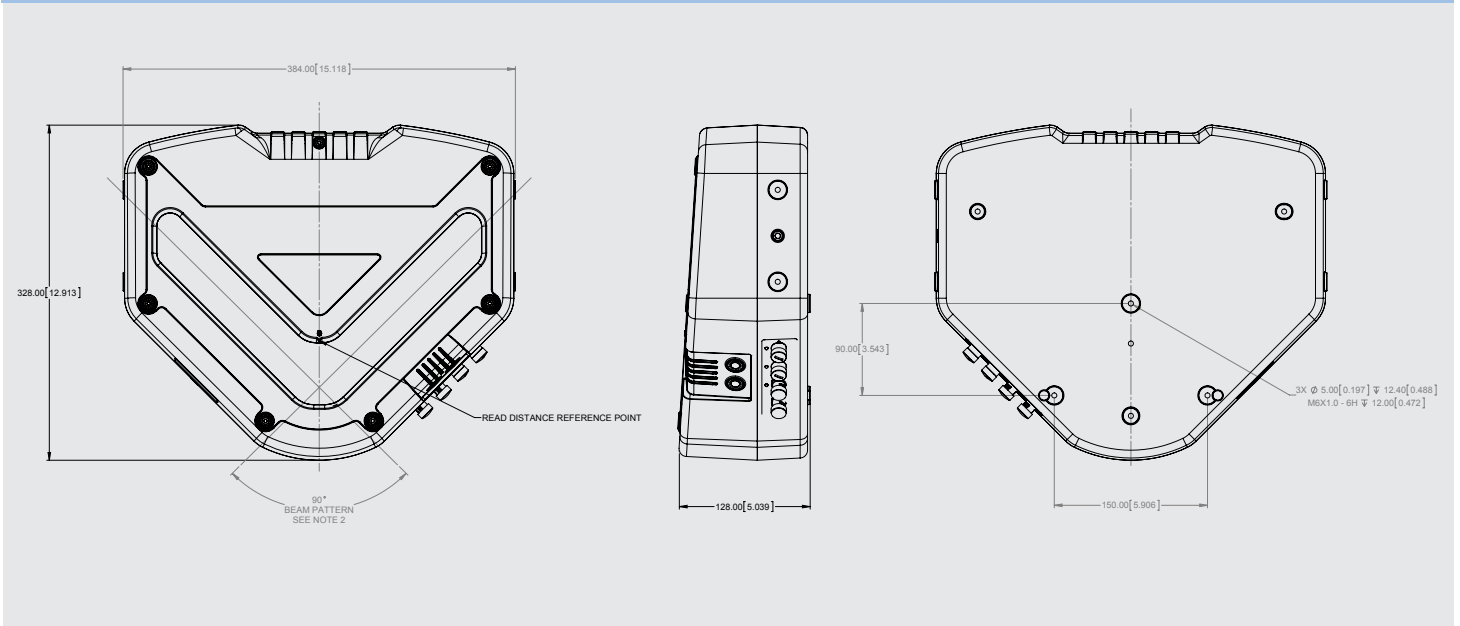

## MODELS

MODEL	DESCRIPTION	PART NUMBER
DX8210-2100	Standard Resolution	936300001
DX8210-4100	Standard Resolution Extended	936300003
DX8210-4200	High Resolution Extended	936300004



BARCODE  
FACTORY

## **Barcode Factory**

*A Paragon Print Systems Company*

**2021 Paragon Drive | Erie PA 16510**  
**814.456.8331 | Toll Free: 888.237.8525**  
**info@barcodefactory.com**