

Blade



Cutting edge traceability with Blade, revolutionary compact 1D reader



Blade Series is the new generation of Compact Industrial 1D Readers designed for lean integration, simple installation and reduced maintenance.

Blade represent the R-Evolution of heroic DS2X000 Series:

- Revolution: Blade is adopting Imaging technology (no laser, no moving parts, all electronics) ensuring maximum reading performances over 1D barcodes and unsurpassed reliability.
- Evolution: Blade is fully backward compatible in terms of mechanical installation and reading coverage (distance, barcode resolution, connectivity) with DS2x00.

Blade models provide ready-to-use, cutting edge solutions supporting a variety of Traceability applications in OEM, Factory and Warehousing Automation, whenever 1D barcodes are in use.

Main Sub-Industry targets are Packaging (Pharma, Food & Beverage) and Intralogistics (Warehouse Automation and general Intralogistics).

Main applications: Tote Routing, primary and secondary packaging traceability, end of line traceability/sorting. The Series is made of two product versions, Blade 100 and Blade 200, offering increasing reading power and flexibility to efficiently match different application needs.



HIGHLIGHTS

POWER OF IMAGING

- Camera sensor 2000 x 128 pixels and innovative lighting system
- Improved reliability, increased reading performances on poor quality labels and 50% reduction of models

LEAN INTEGRATION

- Small size, various fixing points and embedded flexibility allows different positions and orientations
- Smooth transition from DS2X00 to Blade ensured through same mechanical dimensions, positioning and performance

SIMPLE INSTALLATION: FIX-PLUG-GO

- **FIX** is easy, every needed position/angle is supported by multiple fixing point
- **PLUG** M12 connectors for both I/O and Networking. Three options available: single port TCP/IP ETHER-NET plus Legacy RS-232, Double PORT PROFINET and Double Port ETHERNET/IP
- **GO**: switch on and BLADE is ready to start. No image calibration needed. Blade is configured via DL.CO-DE, the standard tool for Matrix Series

REDUCED MAINTENANCE

- Elimination of moving parts: full electronics components will improve product lifetime and reduce total cost of ownership
- In case of replacement configuration backup/restore is available both over the Network and locally via the new MicroSDCard slot
- Complete Monitoring options are offered: embedded WebMonitor (same as Matrix Series) freely accessible and connection to WebSentinel Plus ecosystem

APPLICATIONS

- Automatic warehouses
- General intralogistics
- Tote routing
- Factory automation
- Automatic picking systems
- Process control and packaging traceability (Pharma, Food & Beverage)
- Print & Apply systems
- End of line traceability/sorting

TECHNICAL DATA

COMPACT INDUSTRIAL 1D READERS	BLADE 100		BLADE 200	
	-X1XX MODELS	-X2XX & -X3XX MODELS	-X1XX MODELS	-X2XX & -X3XX MODELS
Reading Distance (Min / Max)	40 - 320 mm / 1.57 - 12.6 in		40 - 600 mm / 1.57 - 23.62 in	
Max Resolution	up to 0.1 mm (3.94 mils)			
Frame Rate	270 frames per second			
Aperture Angle	47°			
Readable Codes	Code 12 of 5, Code 39, Code 93, Code 128, EAN/UPC, GS1 128 (EAN 128), Codabar, Pharmacode, Plessey, ISBT128			
Case Material	Aluminum			
Dimensions (Typical Value)	104 x 68.5 x 38.5 mm (conn .0°)	104 x 86 x 38.5 mm (conn .0°)	104 x 68.5 x 38.5 mm (conn .0°)	104 x 86 x 38.5 mm (conn .0°)
Weight	310 g / 10.93 oz			
Temperature Range	0° - 50 °C / 32 - 122 °F			
Max Power Consumption	4.5 W		5.5 W	
Voltage Supply/Power Consumption	10-30 VDC			
IP Rating	IP65			
Embedded Communication Interfaces	Ethernet TCP/IP Main port RS-232 Auxiliary port RS-232	Dual Port Profinet, conformance Class B (-X3XX) or Dual Port Ethernet-IP (-X2XX)	Ethernet TCP/IP Main port RS-232/RS-422/ RS-485 Auxiliary port RS-232	Dual Port Profinet, conformance Class B (-X3XX) or Dual Port Ethernet-IP (-X2XX)
Digital Inputs	2 Inputs (optocoupled, NPN/PNP)	1 Input (optocoupled, NPN/PNP)	2 Inputs (optocoupled, NPN/PNP)	1 Input (optocoupled, NPN/PNP)
Digital Outputs	2 Outputs		2 Outputs	
Id-Net™ Interface	✓		✓	
Xpress Interface™	✓			
Device Programming	DL.Code			

READING DIAGRAMS

Blade 100 - 2XXX

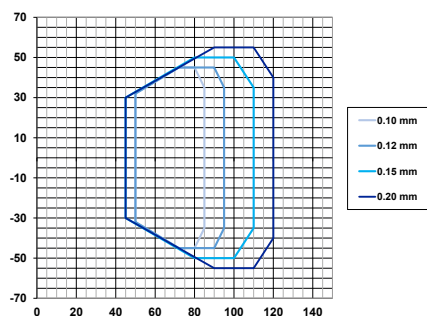

Blade 100 - 1XXX

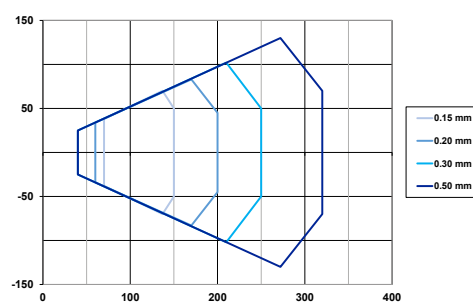

Blade 200 - 1XXX - focus=near

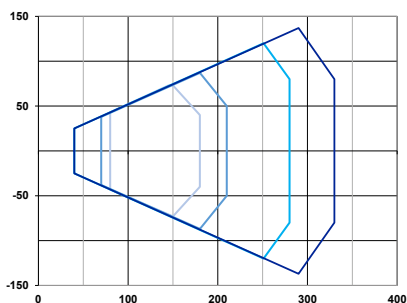

Blade 200 - 1XXX - focus=mid

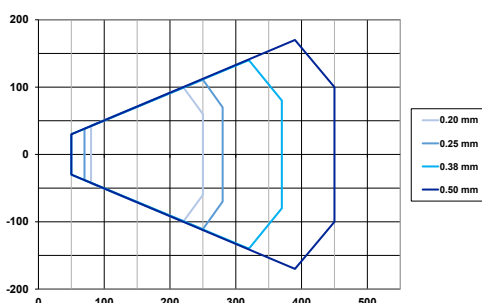

Blade 200 - 1XXX - focus=far

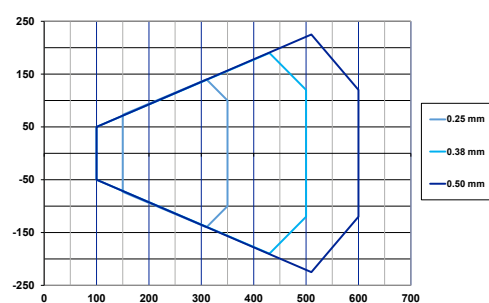

DIMENSIONS

BLADE 100 - 200
ETHERNET SINGLE PORT
FRONT WINDOW

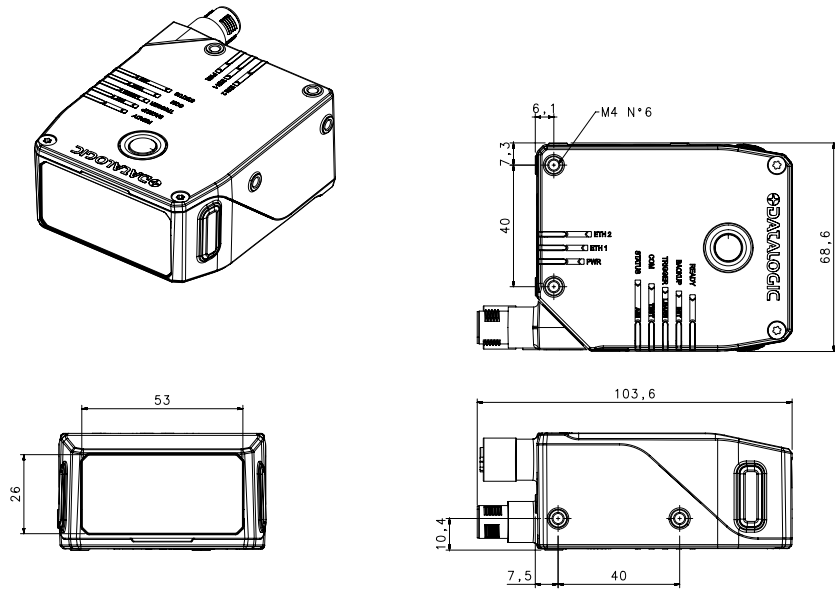

BLADE 100 - 200
PROFINET ETH-IP DOUBLE PORT
SIDE WINDOW

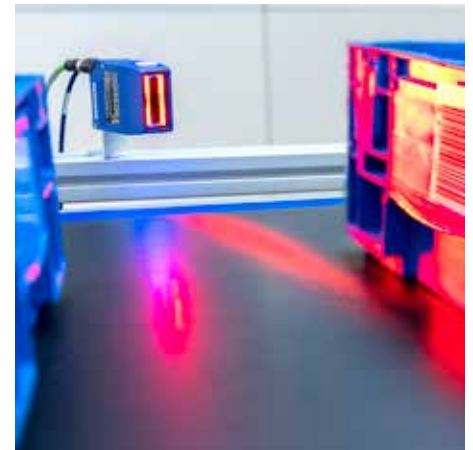
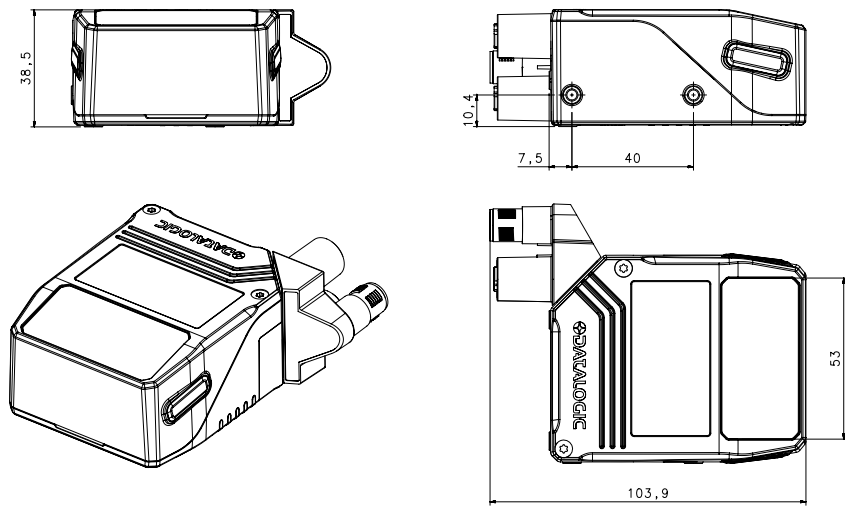



BARCODE
FACTORY

Barcode Factory

A Paragon Print Systems Company

2021 Paragon Drive | Erie PA 16510
814.456.8331 | Toll Free: 888.237.8525
info@barcodefactory.com