

# GRYPHON™ 4500 FIXED SERIES

## Compact scan modules for value-added integrated solutions using 1D and 2D barcodes

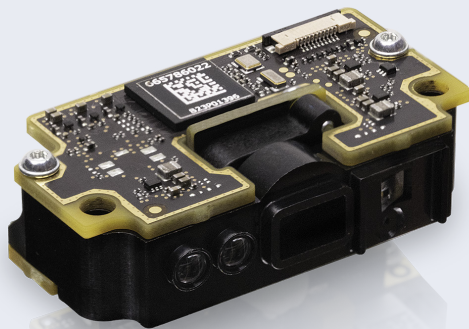

### EASY INTEGRATION

Designed for easy integration and simple installation, the Gryphon 4500 Fixed Series scan modules provide ready-to-use versatile solutions for kiosks and machine manufacturers. The GFS4500 module can be easily integrated with little effort in different enclosures from multiple sides with its small regular size and various fixing points. The “naked” version GFE4500 is ideal for tailor-made fully integrated solution.

### MAXIMUM RELIABILITY

The Gryphon 4500 Fixed Series scan modules are made to last with a durable design for maximum uptime. You can rely on them for both indoor and outdoor applications with the IP54 sealing, the UV protected scratch resistant output window, the wide range operating temperature and the great resistance to accidental drops, shock, and vibrations. RS-232 and USB/RS-232 models have an integrated cable while the USB models are equipped with a locking clip to prevent the USB cable from coming loose or disconnecting.

The 5-year factory warranty proves the Gryphon 4500 Fixed Series has been designed to last.

### TOP PERFORMANCE

The Gryphon 4500 Fixed Series 2D scan modules features the most advanced Megapixel sensor technology with distinctive red or white illumination technology with adjustable brightness for outstanding reading performance. The wide angle optics allows snappy scanning of any 1D and 2D barcodes and it starts reading at almost contact while offering improved motion tolerance and first pass decoding of fast-moving codes. The speedy reading of tickets, boarding passes, loyalty cards, and coupons from mobile phone displays is granted by the ultimate decoding algorithms you can count on.

### BEST FEEDBACK

Datalogic’s ‘Green Spot’ technology coupled with a high visibility top-front LED and integrated loud beeper with adjustable intensity provide superior good-read feedback.

## FEATURES

- Compact dimensions for easy installation and simple integration
- Wide angle 1 MP optics for superior scanning and Depth of Field
- Advanced motion tolerance optics for first pass reading of any moving barcode
- Automatic sensing, software, external, manual trigger options available
- Datalogic distinctive red or white illumination technology with adjustable brightness
- Intuitive Blue Dot LED aimer for easier targeted scanning
- Superior good-read feedback (Datalogic’s ‘Green Spot’ technology, high visibility top-front LED and integrated beeper with adjustable intensity)
- Omnidirectional reading of 1D, 2D and postal codes plus stacked, composite codes and dot codes; Digital Watermarks on red illumination models
- Image capture and document scanning capabilities
- USB, RS-232, USB/RS-232 communication options
- 1 Digital input plus 1 Digital output software programmable (available on specific models)
- Water and Particulate Sealing Rating: IP54
- Disinfectant-Ready enclosure withstands cleaning with harsh disinfectant solutions
- EASEOFCARE Service Plans offer a wide range of service options to protect your investment, ensuring maximum productivity and ROI.

## INDUSTRY-APPLICATIONS

- **OEM Applications:**
  - Self-service kiosks
  - Smart lockers
  - Totems / Info points
  - Airline self-check-in
  - Ticket checkers
  - Turnstiles/Automatic gates
  - Access control
  - Reverse vending machines for recycling
- **Retail Applications:**
  - POS checkout auxiliary scanner
  - Price verifiers
- **Automated Equipment:**
  - Print and apply label verification
- **HealthCare Applications:**
  - Chemical and biomedical analysis machines



# GRYPHON 4500 FIXED SERIES

## TECHNICAL SPECIFICATIONS

### DECODING CAPABILITY

<b>1D / Linear Codes</b>	Auto discriminates all standard 1D codes including GS1 DataBar™ linear codes.
<b>2D Codes</b>	Aztec Code; China Han Xin Code; Data Matrix; MaxiCode; Micro QR Code; QR Code; Dot Code; Dot Matrix
<b>Postal Codes</b>	Australian Post; British Post; China Post; IMB; Japanese Post; KIX Post; Planet Code; Postnet; Royal Mail Code (RM4SCC)
<b>Stacked Codes</b>	EAN/JAN Composites; GS1 DataBar Composites; GS1 DataBar Expanded Stacked; GS1 DataBar Stacked; GS1 DataBar Stacked Omnidirectional; MacroPDF; MicroPDF417; PDF417; UPC A/E Composites
<b>Digital Watermarking</b>	Digimarc Barcodes

### ELECTRICAL

<b>Current</b>	Operating (Typical): < 225 mA Standby/Idle (Typical): Automatic Object Sense Mode: 115 mA Online & Serial OnLine Modes: 55 mA
<b>Input Voltage</b>	GFS4520: 5 VDC +/- 5%; GFS4550/GFX4590: 5 - 14.0 VDC

### ENVIRONMENTAL

<b>Ambient Light</b>	0 – 120,000 lux
<b>Drop Resistance</b>	Withstands repeated drops from 1.5 m / 5 ft onto a concrete surface
<b>Vibration Resistance</b>	Tolerates random vibration, 5 G, from 22 Hz to 300 Hz, 2 hours / 3 axes
<b>Particulate &amp; Water Sealing</b>	IP54
<b>Temperature</b>	Operating: GFS4500: -20 to 50 °C / -4 to 122 °F (suitable up to 55 °C / 131 °F) GFE4500: -20 to 60 °C / -4 to 140 °F Storage/Transport: -40 to 70 °C / -40 to 158 °F

### INTERFACES

<b>Interfaces</b>	GFS4520: USB (micro-USB connector) GFS4550: RS-232 (2 m straight cable DB9 connector) GFS4590: USB / RS-232 (10 cm cable RJ-50 connector) GFE4590: USB / RS-232 (12 pin connector)
<b>Digital I/O</b>	GFS4550 / GFE4590: One SW Programmable digital input plus one SW programmable digital output

### PHYSICAL CHARACTERISTICS

<b>Colors Available</b>	Black; Other colors and custom logo options are available for minimum quantity purchase.
<b>Dimensions</b>	GFS4500: 2.8 x 4.8 x 5.5 cm / 1.1 x 1.9 x 2.2 in GFE4500: 2.0 x 2.7 x 4.8 cm / 0.8 x 1.1 x 1.9 in
<b>Weight</b>	GFS4520: 52 g / 1.8 oz (micro-USB connector) GFS4550: 152 g / 5.4 oz (2 m straight cable DB9 connector included) GFS4590: 95 g / 3.4 oz (10 cm cable RJ50 connector included) GFE4590: 17 g / 0.6 oz (12 pin connector)

### READING PERFORMANCE

<b>Image Capture</b>	Graphic Formats: BMP, JPEG, TIFF; Greyscale: 256, 16, 2
<b>Image Sensor</b>	1 Megapixel: 1280 x 800 pixels
<b>Field of View</b>	51°H, 32°V
<b>Light Source</b>	Aiming: Blue LED's 470 nm Illumination: Red LED 617nm (GFX45XX-RED models); Warm white LED (GFX45XX-WHT models)
<b>Print Contrast Ratio (Min.)</b>	15%
<b>Motion Tolerance</b>	70 IPS (EAN/UPC)
<b>Frame Rate</b>	60 full-frame/s
<b>Reading Angle</b>	Pitch: +/- 60°; Roll (Tilt): +/- 180°; Skew (Yaw): +/- 60°
<b>Reading Indicators</b>	Beeper (Adjustable Tone and volume); Datalogic 'Green Spot' Good Read Feedback; Top-Front Good Read LED (Adjustable brightness)
<b>Resolution (Maximum)</b>	1D Linear: 0.076 mm / 3 mils Data Matrix: 0.13 mm / 5 mils PDF417: 0.13 mm / 5 mils

### READING RANGES

<b>Typical Depth of Field</b>	Minimum distance determined by symbol length and scan angle. Printing resolution, contrast, and ambient light dependent. Code 39: 5 mil: 4 to 30.0 cm / 0.16 to 11.8 in Code 39: 10 mil: 1.7 to 53.5 cm / 0.6 to 21.0 in Data Matrix: 10 mil: 3.5 to 23.5 cm / 1.3 to 9.6 in Data Matrix: 15 mil: 3.0 to 35.0 cm / 1.2 to 13.7 in EAN/UPC: 13 mil: 4.0 to 82.0 cm / 1.6 to 32.3 in PDF417: 10 mil: 1.5 to 35.0 cm / 5.9 to 13.7 in QR Code: 10 mil: 3.5 to 22.0 cm / 1.4 to 8.7 in
-------------------------------	---

### SAFETY & REGULATORY

<b>Agency Approvals</b>	The product meets necessary safety and regulatory approvals for its intended use. The Quick Reference Guide for this product can be referred to for a complete list of certifications.
<b>Environmental Compliance</b>	Complies to China RoHS; Complies to EU RoHS
<b>LED Classification</b>	Illuminator Exempt group, Aiming Risk Group 1 according to IEC 62471

### UTILITIES

<b>Datalogic Aladdin™</b>	Datalogic Aladdin configuration program is available for download at no charge.
<b>OPOS / JavaPOS</b>	OPOS and JavaPOS Utilities are available for download at no charge.
<b>Remote Host Download</b>	Lowers service costs and improves operations.

### WARRANTY

<b>Warranty</b>	5-Year Factory Warranty
-----------------	-------------------------

GFS4500

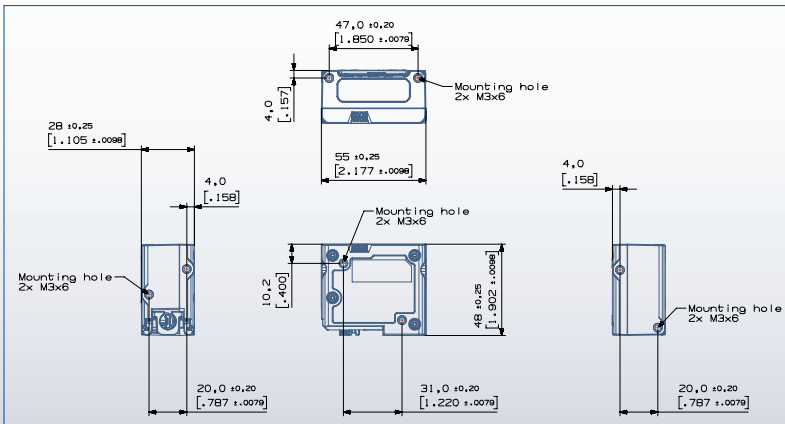

GFE4500

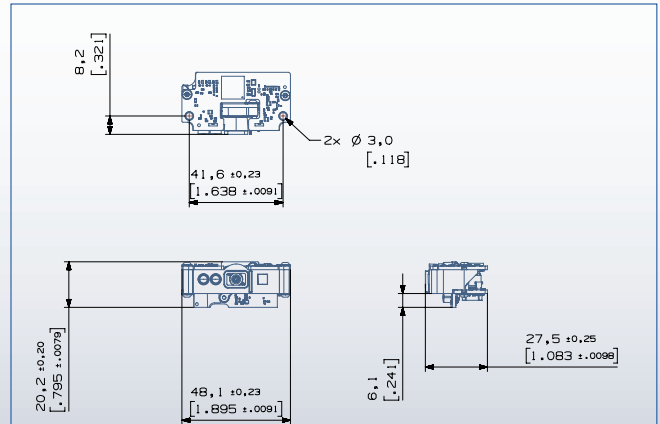



BARCODE  
FACTORY

## **Barcode Factory**

*A Paragon Print Systems Company*

**2021 Paragon Drive | Erie PA 16510**  
**814.456.8331 | Toll Free: 888.237.8525**  
**info@barcodefactory.com**