

MATRIX 120™



The Matrix 120 is the smallest ultra-compact industrial 2D imager range in the market to fit any integration space and the smallest compact 2D imager with embedded Ethernet connectivity.

The Matrix 120 is available in different models, including a WVGA sensor for standard applications or a 1.2 MP sensor for high resolution bar codes. Moreover, a wide angle version makes the Matrix 120 the perfect solution for proximity reading.

The Matrix 120 with the red light model is the first stationary industrial scanner in the market able to read Digimarc Barcode for added value decoding applications.

The Matrix 120 features the top industrial grade parts in its class (IP65 and 0-45 °C / 32 – 133 °F), with ESD safe models for applications in the electronic industry and a glass-free reading window, suitable for the Food and Beverage environment.

Sulfur gas protection allows the use of Matrix 120 in tires applications through rough manufacturing, final finishing and inspection stations.

As part of the full Matrix series, the Matrix 120 leads the market for customer ease of use because of DL.CODE™ configuration software, X-Press™ button and intuitive HMI.

The Matrix 120 is the entry level model of the best-in-class Matrix family of high performance industrial 2D imagers.

The Matrix 120 is the perfect solution when small dimension, simple integration and performance are the key drivers. The Matrix 120 models with shorter output cables (only 100 mm of length) allow an easier integration in OEM machines, making this product ideal for customers belonging to Chemical/Biomedical Industry and Print & Apply applications. Additionally, this imager is perfect for entry level applications in the Factory Automation arena: Electronics, Packaging and Food/Beverage.



HIGHLIGHTS

- Ultra compact dimensions for easy integration
- WVGA – 1.2 MP and wide angle models
- Smart user selectable focus for high application flexibility
- Digimarc Barcode reading technology for added value decoding applications
- Embedded Ethernet connectivity
- Serial and USB options on the same model
- ESD versions for electronic applications
- Polarized Version for 90° mounting and reflecting surfaces
- Models equipped with shorter output cables (100mm of length) for easier integration in OEM machines
- Top industrial grade: IP65; operating temperatures: 0-45 °C / 32 – 133 °F
- DL.CODE software configurator for outstanding ease of setup
- Xpress, Datalogic's 'Green Spot' technology and intuitive HMI for top ease of use

APPLICATION

- Electronics: Track and trace PCB board manufacturing
- Factory Automation: Print & Apply – label verification
- Factory Automation: Food & Beverage – traceability
- OEM: Kiosks: ticketing machine
- Healthcare: Clinical Lab – vials identification
- Chemical and biomedical analysis machine

TECHNICAL DATA

OPTICAL FEATURES		ELECTRICAL FEATURES	
Sensor	CMOS sensor with Global Shutter/WVGA - 752x480 px CMOS sensor with Global Shutter/1.2 MP - 1280x960 px	Power Supply Voltage	5-30 VDC;
Frame Rate	up to 57 full-frame/s (WVGA model) , up to 36 full-frame/s (1.2 MP model)	Max Power Consumption	1.6 to 2.4 W
Illumination	White Internal Illuminator	PHYSICAL CHARACTERISTICS	
Focusing System	Manual adjustment in three precalibrated positions (45, 70, 125mm - WVGA ; 45, 80, 125mm - 1.2 MP)	Dimensions	45.4 x 31.1 x 23.5 mm [1.8 x 1.2 x 1 in] (SER+USB model) 45.4 x 48.5 x 23.5 mm [1.8 x 1.9 x 1 in] (SER+ETH model) Cable Versions: STD 1000mm (39 in), SC 100mm (3.9 in)
Polarizer filter	Available on dedicated models	Weight	Standard cables 117g (4.1 oz) with cable (SER+USB model) - 200g (7.1 oz) with cable (SER+ETH model) Short Cables 96 g (3.4 oz) with cable (SER+USB model) - 145 g (5.1 oz) with cable (SER+ETH model)
Pitch	+/- 35°	Case Material	Aluminum
Tilt	0° - 360°(within vertical FOV)	ENVIRONMENTAL FEATURES	
DECODING CAPABILITY		Humidity	90% non condensing
Readable Symbolologies	Omnidirectional reading on any of the following codes: 1D Codes: all standard 1 dimensional symbologies 2D Codes: Data Matrix, QR Code, Micro QR, Maxicode, Aztec, Dot Code Postal Codes: Royal Mail, Japan Post, Planet, Postnet and many more Digimarc Barcode: DWCODE™	Protection Class EN60529	IP65
Reading capability	Omnidirectional on any code type Multilabel / multicode reading	Operating Temperature	0-45 °C / 32 – 113 °F
Code Quality Metrics	1D CQ Standard: ISO/IEC 15416 2D CQ Standard: ISO/IEC 16022/18004, ISO/IEC 29158 (AIM-DPM), ISO/IEC 15415	Storage Temperature	-20 to 70 °C (-4 to 158 °F)
Code Quality Metrics	1D CQ Standard: ISO/IEC 15416 2D CQ Standard: ISO/IEC 16022/18004, ISO/IEC 29158 (AIM-DPM), ISO/IEC 15415	Sulfur gas resistance	Available for all the models according to ISO EN 60068-2-43
COMMUNICATIONS INTERFACE		ESD Safe	Available on dedicated models
Embedded communication interfaces	Main RS-232 or RS-422 FD (2400 to 115200 bit/s) SER+ETH models: RS-232/RS-422/Ethernet 10/100 Mbit/s with protocols TCP/IP, UDP, FTP and Fieldbus PROFINET IO, Ethernet IP, Modbus TCP SER+USB models: RS-232/RS-422/USB 2.0 high speed (USB-CDC, USB-HID)	SAFETY & REGULATORY	
Digital Inputs	Two SW Programmable (PNP/NPN)	Agency approvals	The product meets necessary safety and regulatory approvals for its intended use.
Digital Outputs	Two SW Programmable (PNP/NPN)	Environmental compliance	Complies to EU RoHS
INPUTS AND OUTPUTS		Regulatory	EN61000-6-2 Electromagnetic Immunity; EN61000-6-4 Electromagnetic Emissions Class A; FCC part 15 for Class A digital device; CSA listed product for Canada and U.S.; CE; KC; EAC Class 1M Laser Product as per IEC 60825-1 Complies with CDRH Requirements
Operating Mode	Continuous, One Shot, Phase mode	Laser Safety	LED Safety Exempt Risk Group as per EN 62471
Aiming System	Laser indicator	WARRANTY	
User Interface	<ul style="list-style-type: none"> Green spot X-PRESS™ Human Machine Interface Beeper X-PRESS™ Push Button 6 LEDs (Power; Ready, Good, Trigger, Com, Status, Ethernet Network) 	Warranty	2-Year Factory Warranty
Device Programming	DL.CODE™ Windows-based software (programming via Ethernet or Serial Interface) with Javascript output formatter Serial Host Mode programming X-PRESS™ Human Machine Interface		



Pharma

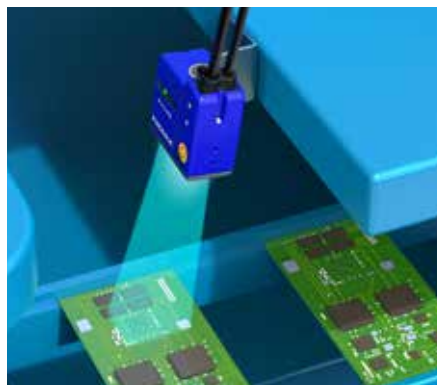

Electronics

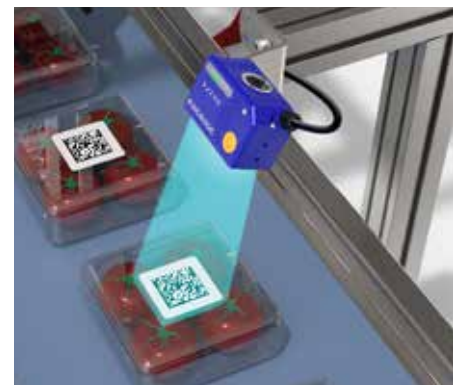

Food & Beverage

DIMENSIONS

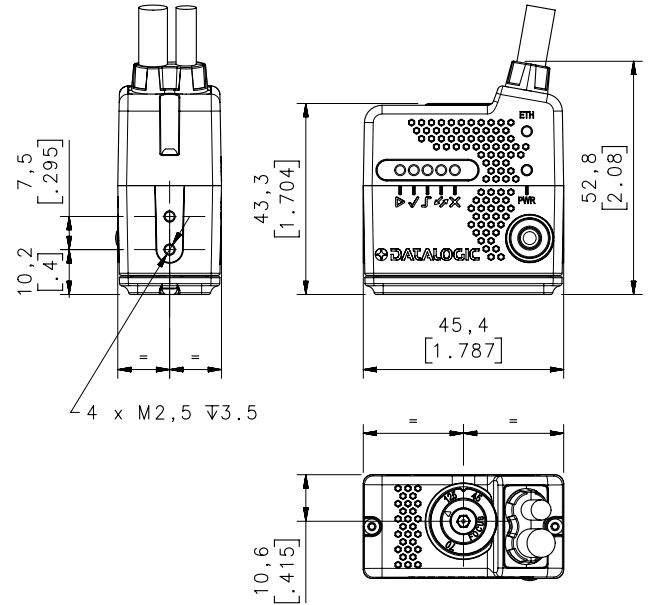
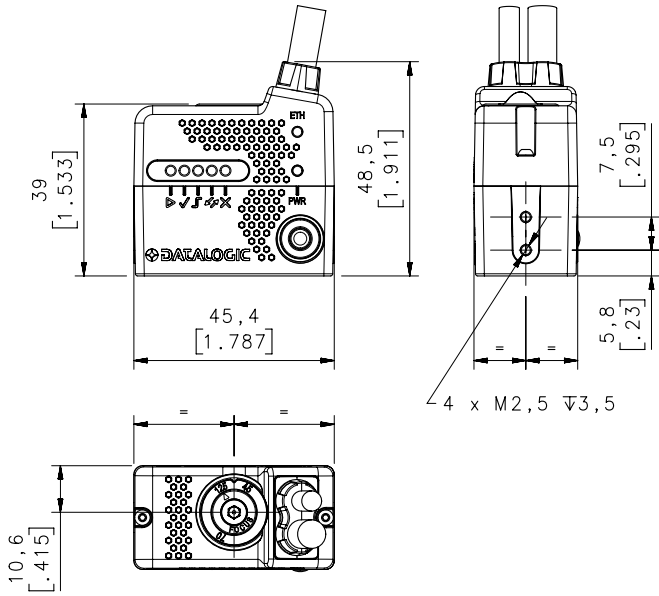
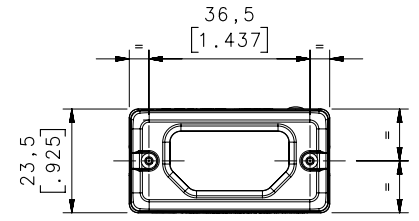
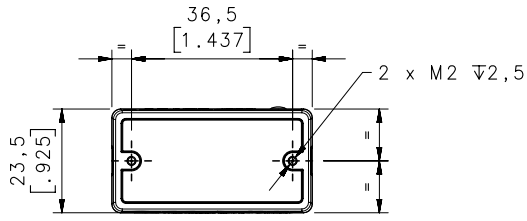

Matrix 120 Ethernet Models

Matrix 120 Ethernet Models with ESD Cover

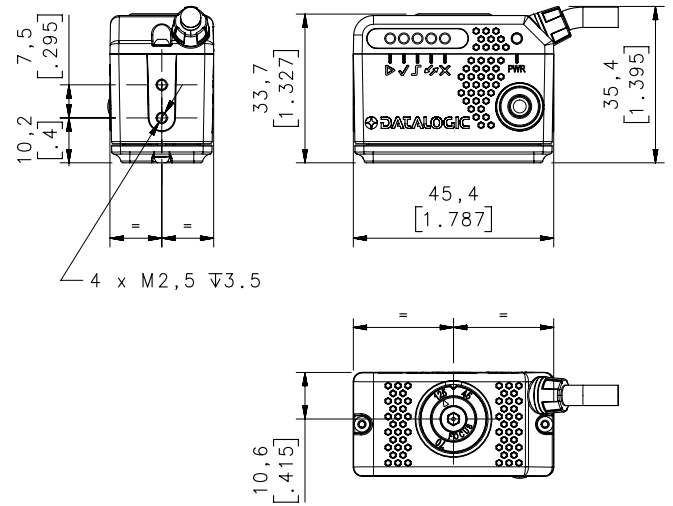
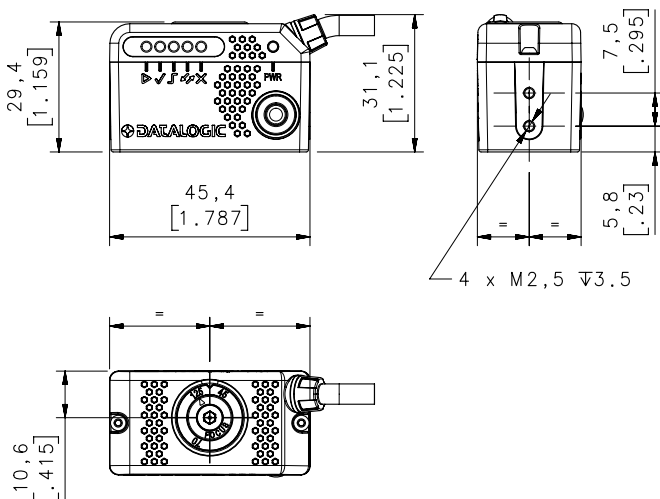
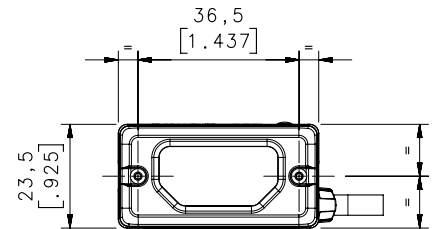
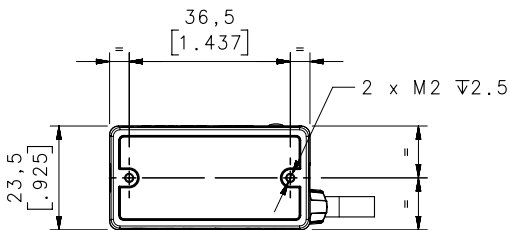

Matrix 120 USB Models

Matrix 120 USB Models with ESD Cover

MODELS

CODE	DESCRIPTION	SENSOR	CONNECTIVITY	TYPE
937800000	MATRIX 120 210-000 WVGA SER+USB STD	WVGA	SER+USB	STD
937800001	MATRIX 120 210-010 WVGA SER+ETH STD	WVGA	SER+ETH	STD
937800002	MATRIX 120 210-001 WVGA SER+USB ESD	WVGA	SER+USB	ESD
937800003	MATRIX 120 210-011 WVGA SER+ETH ESD	WVGA	SER+ETH	ESD
937800004	MATRIX 120 310-001 1.2MP SER+USB ESD	1.2MP	SER+USB	ESD
937800005	MATRIX 120 310-011 1.2MP SER+ETH ESD	1.2MP	SER+ETH	ESD
937800006	MATRIX 120 210-100 WVGA SER+USB 1D	WVGA	SER+USB	STD 1D
937800007	MATRIX 120 210-110 WVGA SER+ETH 1D	WVGA	SER+ETH	STD 1D
937800008	MATRIX 120 311-000 1.2MP SER+USB WA	1.2MP	SER+USB	WA
937800009	MATRIX 120 311-010 1.2MP SER+ETH WA	1.2MP	SER+ETH	WA
937800010	MATRIX 120 311-100 1.2MP SER+USB WA 1D	1.2MP	SER+USB	WA 1D
937800011	MATRIX 120 311-110 1.2MP SER+ETH WA 1D	1.2MP	SER+ETH	WA 1D
937800014	MATRIX 120 311-005 1.2 SER+USB WA PLZR	1.2MP	SER+USB	WA+PLZ
937800015	MATRIX 120 311-015 1.2 SER+ETH WA PLZR	1.2MP	SER+ETH	WA+PLZ
937800045	MATRIX 120 310-01A 1.2MP SER+ETH	1.2MP	SER+ETH	Digimarc
937800052	MATRIX 120 210-050 WVGA SER+USB STD SC	WVGA	SER+USB	STD SC
937800053	MATRIX 120 210-060 WVGA SER+ETH STD SC	WVGA	SER+ETH	STD SC
937800054	MATRIX 120 311-050 1.2MP SER+USB WA SC	1.2MP	SER+USB	WA SC
937800055	MATRIX 120 311-060 1.2MP SER+ETH WA SC	1.2MP	SER+ETH	WA SC
937800056	MATRIX 120 311-055 1.2 SER+USB WA PLZ SC	1.2MP	SER+USB	WA+PLZ+SC
937800057	MATRIX 120 311-065 1.2 SER+ETH WA PLZ SC	1.2MP	SER+ETH	WA+PLZ+SC

Legenda:

1D Only linear code
 ESD ESD safe version
 WA Wide Angle Optics
 PLZ Polarizer Version
 SC Short pig tail cable 100mm
 Digimarc Digimarc Version

ACCESSORIES

CODE	DESCRIPTION
93A050099	CAB-1011 M120 M12 Main To CBX (1M)
93A050100	CAB-1021 M120 M12 Main To USB (1M)
93A050108	CAB-1051 M120 M12 Main To USB + I/O (1M)
93A050103	CAB-1001 M120 M12-M12 Main Extension (1M)
93A050104	CAB-1002 M120 M12-M12 Main Extension (2M)
93A050105	CAB-1005 M120 M12-M12 Main Extension (5M)
93A051346	CAB-ETH-M01 M12-IP67 Ethernet Cable (1M)
93A051347	CAB-ETH-M03 M12-IP67 Ethernet Cable (3M)
93A051348	CAB-ETH-M05 M12-IP67 Ethernet Cable (5M)
93A050057	CBL-1534.02 Adapter Cable Ethernet M12 to female RJ45

CABLES

CODE	DESCRIPTION
93A050099	CAB-1011 - M120 M12 Main To CBX (1M)
93A050100	CAB-1021 - M120 M12 MAIN TO USB 1M
93A050108	CAB-1051 - M120 M12 MAIN USB AND I/O 1M
93A050103	CAB-1001 - M120 M12 MAIN EXTENS 1M
93A050104	CAB-1002 - M120 M12 MAIN EXTENS 2M
93A050105	CAB-1005 - M120 M12 MAIN EXTENS 5M
93A051346	CAB-ETH-M01 M12-IP67 ETHERNET CAB. (1M)
93A051347	CAB-ETH-M03 M12-IP67 ETHERNET CAB. (3M)
93A051348	CAB-ETH-M05 M12-IP67 ETHERNET CAB. (5M)
93A050057	CBL-1534-0.2 ADAPT. CABLE ETH M12-TO-RJ4
93A050076	CAB-GD03 M12 F/L 3M
93A050077	CAB-GD05 M12 F/L 5M
93A050078	CAB-GD10 M12 F/L 10M



BARCODE
FACTORY

Barcode Factory

A Paragon Print Systems Company

2021 Paragon Drive | Erie PA 16510
814.456.8331 | Toll Free: 888.237.8525
info@barcodefactory.com